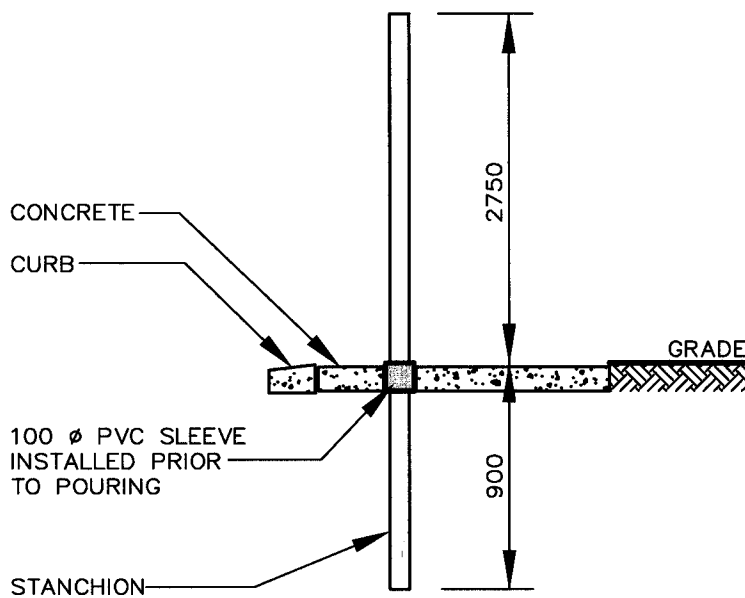

**FIG. 1 - BOULEVARD AREAS**  
N.T.S.



**FIG. 2 - CONCRETE AREAS**  
N.T.S.

**NOTES**

- LOCATION OF SIGNS TO BE AS APPROVED BY TRAFFIC OPERATIONS.
- EXISTING SIGNS TO BE INVENTORIED PRIOR TO CONSTRUCTION.

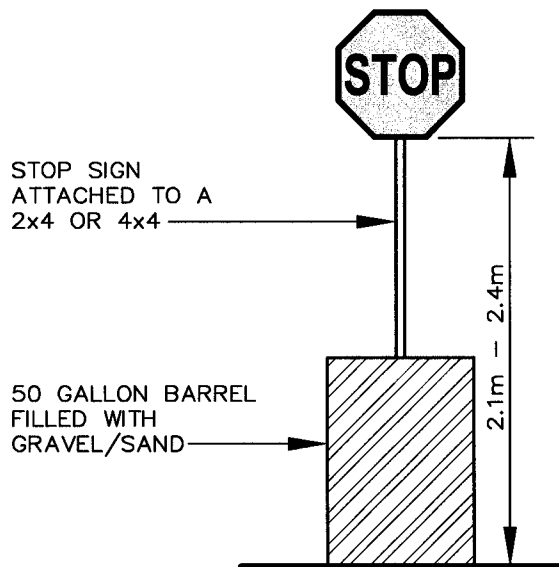

**FIG. 3 - TEMPORARY SIGNS**  
N.T.S.

CITY OF WINDSOR DEPARTMENT OF ENGINEERING	
<b>INSTALLATION METHOD OF TRAFFIC SIGNAGE DISTURBED BY CONSTRUCTION</b>	
DR'N BY: M. BONTORIN	DATE: FEBRUARY 2008
REVISION: JAN. 2011	CH'KD BY:
CH'KD BY: P.R.W.	PASSED BY:
 MARIO BONIEGO, CITY ENGINEER	
<b>AS-538</b>	