

CASE 1 : SEPARATE RAMPS (DESIRABLE)

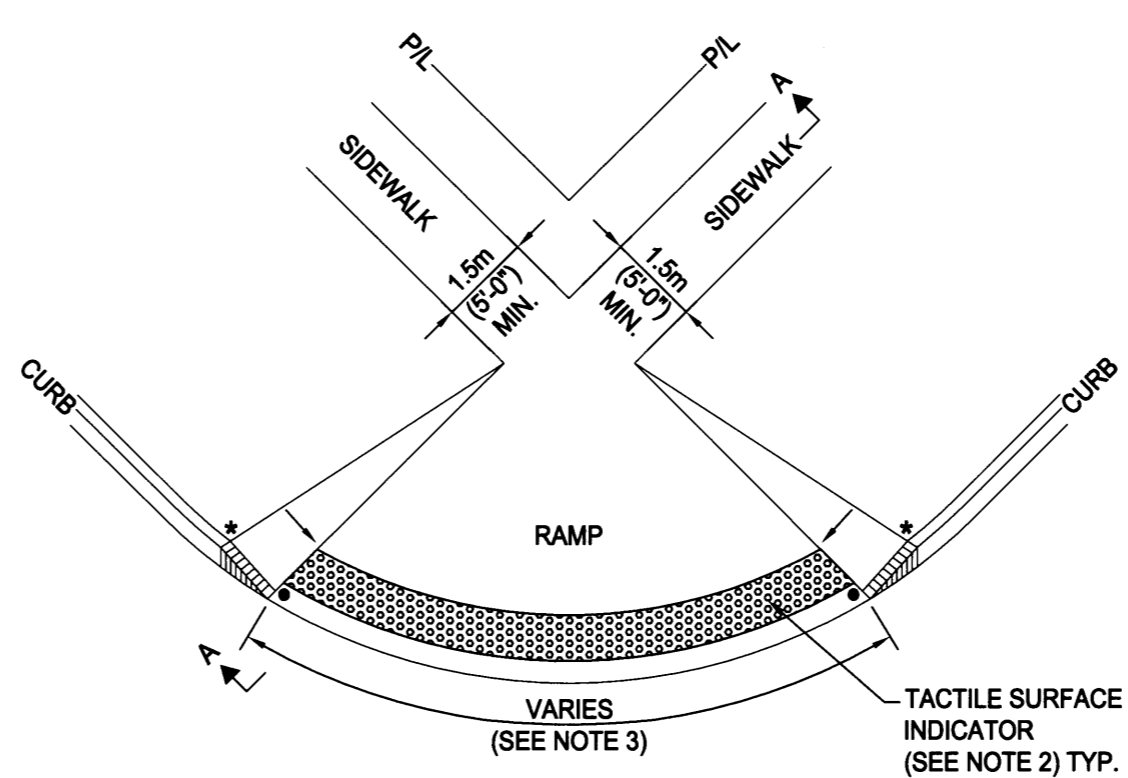

CASE 2 : SHARED RAMP (ACCEPTABLE)

12mm THICK FULL DEPTH JOINT FILLER MATERIAL, MEETING THE REQUIREMENTS OF OPSS-1308

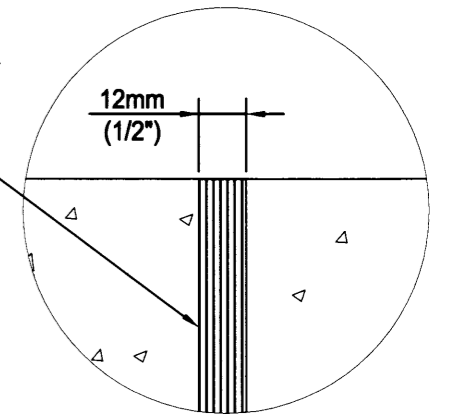

EXPANSION JOINT DETAIL

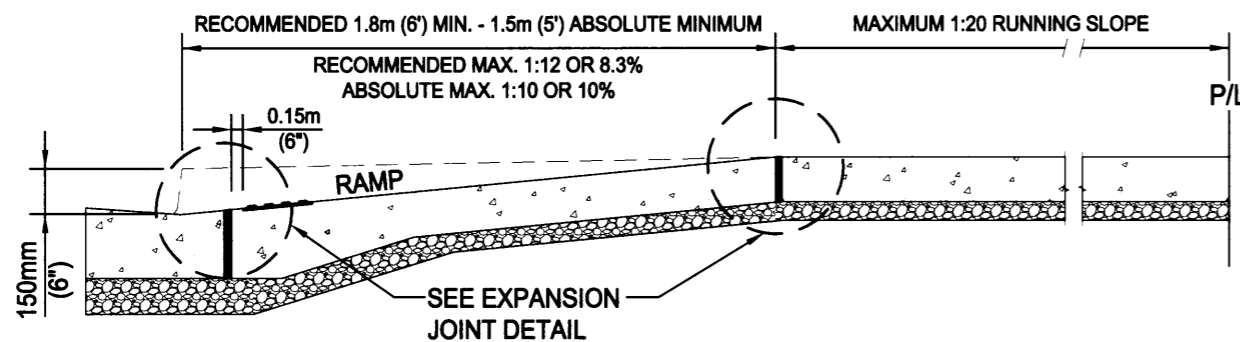

CROSS SECTION A-A

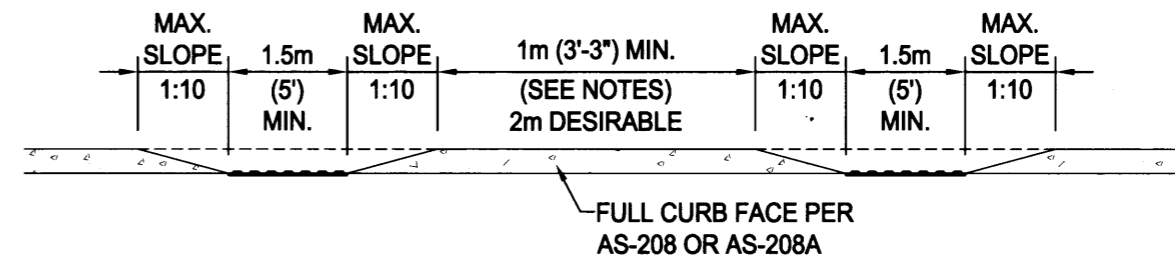

ELEVATION

GENERAL NOTES:

1. The surface texture of the ramp shall be coarse broom finished draining towards the gutter so that it is rougher than the texture of the surrounding sidewalk.
2. The tactile surface indicators shall:
 - i) Be yellow and have a high tonal contrast with the adjacent ramp surface.
 - ii) Extend the full width of the ramp section that is flush with the gutter and not to extend along the flared section.
 - iii) Consist of truncated domes in accordance with AS-549 or other raised tactile profile as approved by the City Engineer.
3. Ramps shall be aligned to provide a direct connection from the sidewalk to the ramp and provide straight-line connection to the ramp on the other side of the street. Where the distance between ramps is less than 1m (3'-3") as shown on Case ①, a shared ramp shall be used (Case ②).

4. The width of a shared ramp shall be determined by aligning each ramp edge with the respective edge on the other side of the crossing in each direction.
 5. Where a painted crosswalk exists, the width of the ramp must match the width of the crosswalk.
 6. To be read in conjunction with AS-401 and AS-403.
 7. All work within public right-of-way to be completed to City of Windsor Standards and to the satisfaction of the City Engineer.
- * elevation to match existing
● elevation to be flush with the gutter

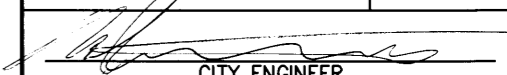
CITY OF WINDSOR ENGINEERING DEPARTMENT	
SIDEWALK WHEEL CHAIR RAMP	
DR'N BY: M.L./M.F./N.B.	DATE: AUG, 2013
REVISION: DEC. 2015, FEB. 2016	CH'KD BY: S.S. / M.C.
CH'KD BY: P.J.U.	PASSED BY:
 CITY ENGINEER	
AS-402	