

FIG. 1 - BOULEVARD AREAS
N.T.S.

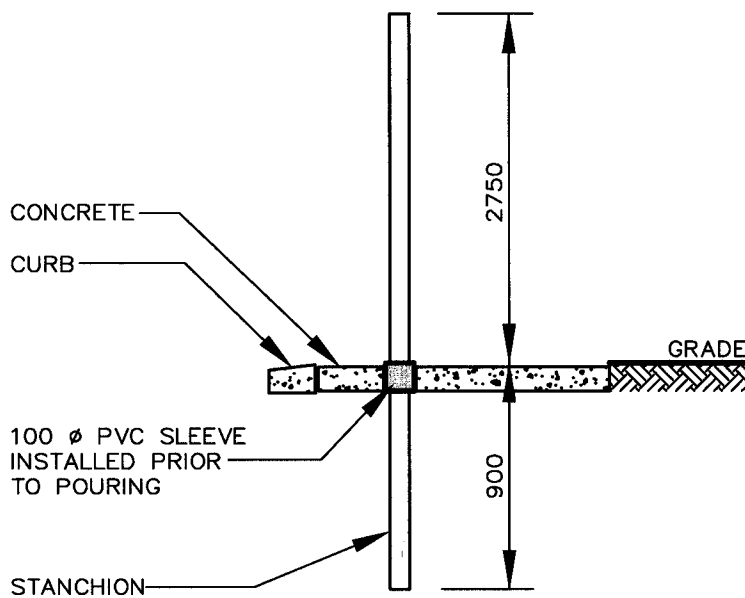

FIG. 2 - CONCRETE AREAS
N.T.S.

NOTES

- LOCATION OF SIGNS TO BE AS APPROVED BY TRAFFIC OPERATIONS.
- EXISTING SIGNS TO BE INVENTORIED PRIOR TO CONSTRUCTION.

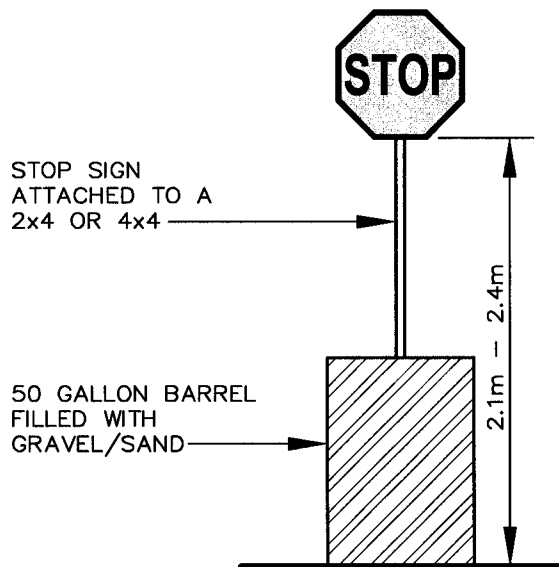



FIG. 3 - TEMPORARY SIGNS
N.T.S.

CITY OF WINDSOR DEPARTMENT OF ENGINEERING	
INSTALLATION METHOD OF TRAFFIC SIGNAGE DISTURBED BY CONSTRUCTION	
DR'N BY: M. BONTORIN	DATE: FEBRUARY 2008
REVISION: JAN. 2011	CH'KD BY:
CH'KD BY: P.R.W.	PASSED BY:
 MARIO BONEGO, CITY ENGINEER	
AS-538	