

SECTION A-A

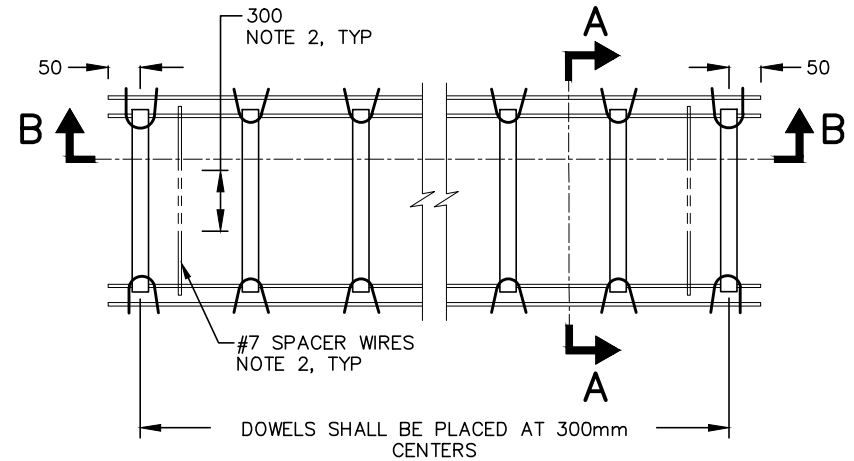

PLAN

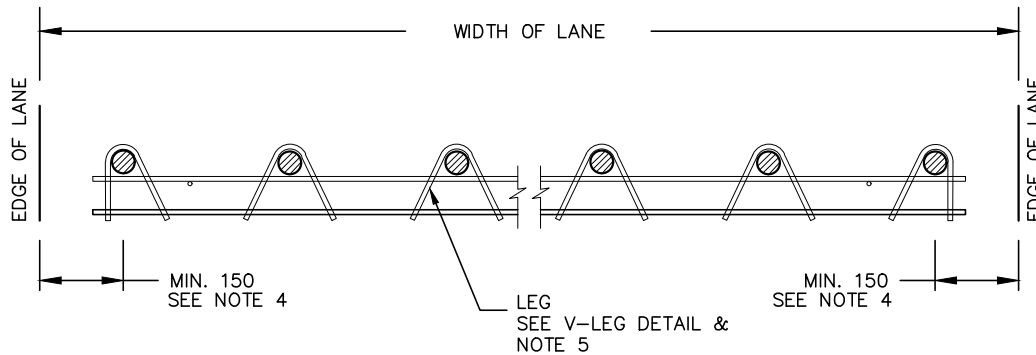

SECTION B-B

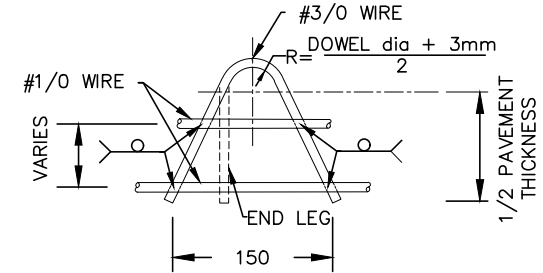

V-LEG DETAIL

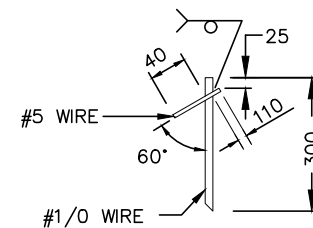

STAKE DETAIL

NOTES:

1. A MINIMUM OF 3 STAKES SHALL BE UNIFORMLY SPACED PER SIDE PER LANE.
 2. SPACER WIRE SHALL BE CUT IN TWO PLACES AND THE MID SECTION REMOVED AFTER STAKING ASSEMBLY IS IN POSITION. SECTION REMOVED SHALL BE A MINIMUM LENGTH OF 300mm.
 3. ARC OR RESISTANCE SPOT WELD, ALTERNATE ENDS OF ADJACENT DOWELS ONLY, TOP OR BOTTOM OF DOWEL BAR.
 4. HORIZONTAL OFFSET FROM EDGE OF LANE TO CENTER OF FIRST DOWEL SHALL BE EQUAL FROM EITHER EDGE OF LANE. HORIZONTAL DIMENSION SHALL BE 150mm MIN. AND LESS THAN 300mm.
 5. U-LEG AND J-LEG ALTERNATIVES MAY BE APPROVED AT THE DISCRETION OF THE CITY ENGINEER.
- A. AT BRIDGE APPROACHES THE LOAD TRANSFER DEVICE SHALL MATCH THE SKEW OF THE APPROACH SLAB.
 - B. LOAD TRANSFER DEVICE SHALL BE SHOP COATED WITH RC-250, TECTYL 506, OR PROTEC 6116-DS AMBER.
 - C. LOAD TRANSFER DEVICES NOT REQUIRED IN SHOULDERS OR GORE AREAS.
 - D. ALL DIMENSIONS ARE IN MILLIMETERS UNLESS OTHERWISE SHOWN.

NOT TO SCALE

 CITY OF WINDSOR ENGINEERING DEPARTMENT	
LOAD TRANSFER DEVICE RIGHT ANGLE CONTRACTION JOINT	
DR'N BY: AZ	DATE: MAY, 2024
REV. DATE:	CH'KD BY (ENG): PM, JH
CH'KD BY (GEO/OPS): PJU, AL	PASSED BY: FM
_____ CITY ENGINEER	AS-212