

PLAN VIEW

GENERAL NOTES:

- 1.) CONCRETE SIDEWALK CONSTRUCTION DETAIL PER AS-401, AS-403
- 2.) AS-552 ONLY APPLICABLE TO SIDEWALK REPAIRS AND TRYING IN NEW SIDEWALKS TO EXISTING AS PER THE DIRECTION OF THE CITY ENGINEER.
- 3.) THE INSTALLATION OF DOWELING JOINT ONLY APPLICABLE TO CONCRETE SIDEWALK, EXCLUDING THE JOINT BETWEEN CONCRETE DRIVEWAY AND SIDEWALK.

DRAFT

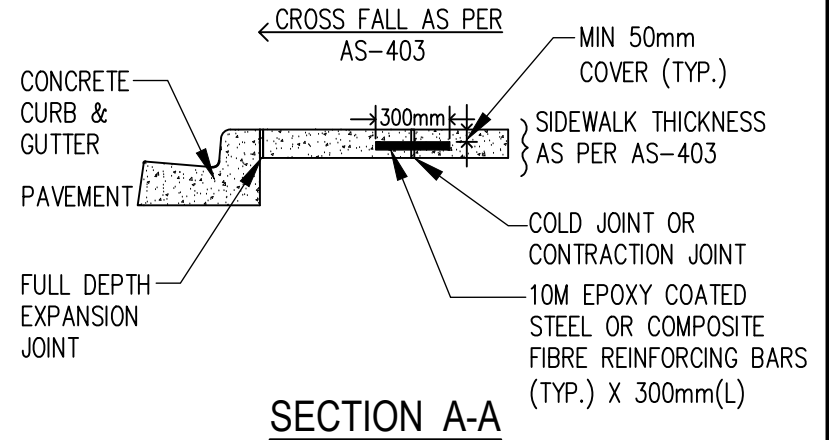

SECTION A-A

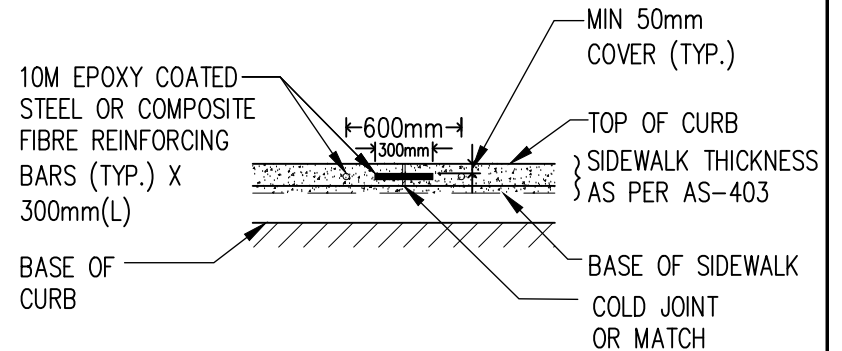

SECTION B-B

CITY OF WINDSOR

ENGINEERING DEPARTMENT

**SIDEWALK JOINTING DETAIL
(REPAIRS & NEW INSTALLS)**

DR'N BY: J.L, B.C	DATE: NOVEMBER 2013
REVISION: AUGUST 2023	CH'KD BY: A.L.
CH'KD BY: P.J.U.	PASSED BY:

Chris Nepszy
CHRIS NEPSZY, CITY ENGINEER

AS-552