

**UTILITY BOX-OUT**

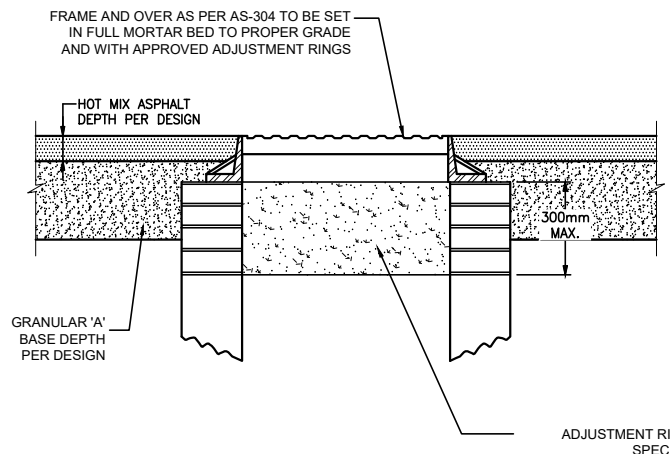

**MANHOLE IN ASPHALT PAVEMENT**

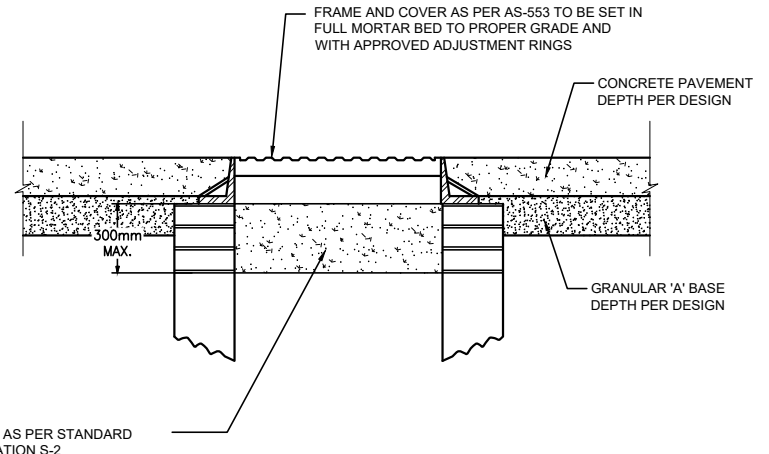

**MANHOLE IN CONCRETE PAVEMENT**

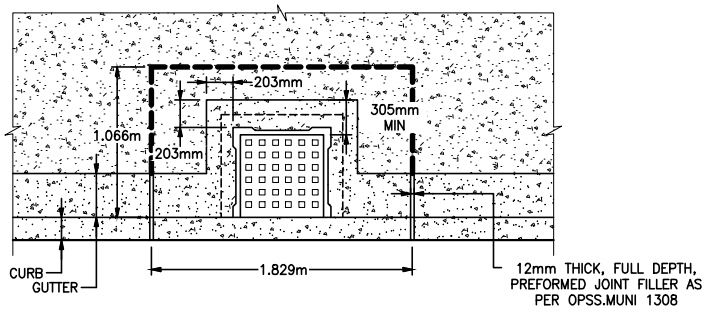

**CATCH BASIN BOX-OUT**

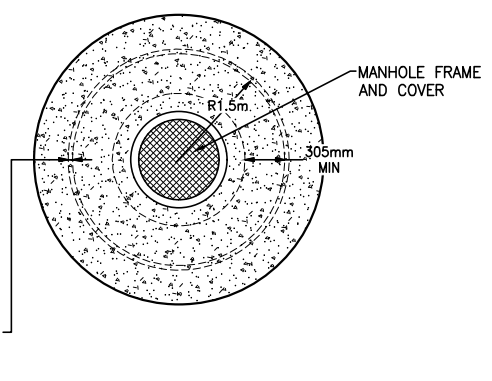

**UTILITY MANHOLE BOX-OUT**

**NOTES:**

- ① ISOLATE ALL STRUCTURES WITHIN THE NEW CONCRETE & BASE AND SIDEWALK USING FULL DEPTH 12mm THICK, PREFORMED FILLER CONFORMING TO OPSS.MUNI 1308.
- ② ALL WORK SHALL CONFORM TO CITY OF WINDSOR SPECIFICATIONS.
- ③ THIS DRAWING SHALL BE READ IN CONJUNCTION WITH S-2.
- ④ SELF LEVELING MAINTENANCE HOLE FRAME & COVER SHALL BE USED IN CONCRETE PAVEMENT, WHERE POSSIBLE. REFER TO AS-553.

 <b>CITY OF WINDSOR</b> ENGINEERING DEPARTMENT	
<b>UTILITY ISOLATION IN PAVEMENT DETAILS</b>	
DR'N BY: LEB, AZ	DATE: AUG, 1972
REV. DATE: MAR, 2024	CH'KD BY (ENG): PM, JH
CH'KD BY (GEO/OPS): PJU, AL	PASSED BY: FM
_____ CITY ENGINEER	
<b>AS-213</b>	

NOT TO SCALE